

A forum for woodworkers of all skill levels to share their common interests

## NORTHWEST WOODWORKERS' GUILD

# THE SAWDUST NEWS

July 2009

### **Next Meeting:**

**Double Feature!**  
**Richard Smith**  
**Shell and Stone**

**Inlay**  
**plus...Picnic!**

**Thursday**

**July 16, 2009**

**5:00 PM**

**Ed and Marly  
Moore's house**

(directions: Page 2)

### **Guild Officers**

President—Jack Martin  
jm4sailing@yahoo.com  
425-885-4282

Treasurer/Membership  
Bob Schaefer  
bobanddoriss@earthlink.net  
206-282-4905

**Programs**  
**Need volunteers Please**

Library—Don Strong  
dswood4fun@aol.com  
206-285-7733

Newsletter—Steve Krauss  
catbert@oz.net  
425-746-5067

## President's Message

— by Jack Martin

If you attended the June meeting and are interested in CNC Routers you had an excellent opportunity to learn first hand from Mike Magruder's excellent knowledge and experience. Mike designed and built his own CNC machine. Although it was not possible for Mike to bring his large machine to the meeting he provided detailed photos, discussed the machine programming and the pros and cons of CNC Routers. Thank you Mike for sharing with us your excellent knowledge and experience of the CNC machine. Also a special thanks to Ron and Michelle Hall (Woodcraft Supply) for hosting the meeting and providing an excellent door prize. **(NOTE: in the August 2009 issue of Woodworkers Journal, on page 54 there is an article titled," CNC Router Magic"**

**Meetings Schedule for July, August, and September 2009:**

**July PICNIC and Meeting at Ed and Marly Moore's house.**

Richard Smith will present a project on how to beautify your project using shells and stones inlays. **Note the time and date change: meeting will start at 5:00 p m on Thursday, 7/16/09 and picnic at follow the meeting. Come early so you can socialize with your fellow woodworkers and their families....directions to the Moore's house are on page 2.**

**August Meeting at Woodcraft Supply on Thursday, 8/27/09 at 6:30 p. m.**

Chris Green will demo how he uses his router to form unique shapes.

**September Meeting at Woodcraft Supply on Thursday 9/24/09 at 6:30 p.m.**

Bill Wiley will present his unique program on Sharpening.

**October Meeting Edensaw on Thursday, 10/29/09 at 6:30 p.m.** Dennis Stickle will host the meeting and provide us with an excellent presentation of Edensaw's product line and a tour of their facility.

**Our next meeting/Picnic will be at Ed and Marly's house on Thursday, 7/16/2009 meeting is at 5:00 p m and the picnic follows the meeting.... Remember to bring your show and tell items. I look forward seeing you on Thursday the 16<sup>th</sup> and remember we are counting on each family to bring a dessert or salad to the picnic...thank you.**

**Important Notice:**

**We are holding our election of Officers in September and if you are interested in being a candidate: contact a committee member: Don Strong- 206 - 285 7733, Rick**

**Tydings 206-232-6916 or Jack Martin- 425 885 4282- A list of positions will be sent to you soon.**



A forum for woodworkers of all skill levels to share their common interests



Northwest Woodworkers Guild  
Steve Krauss, Newsletter Editor  
16204 Main St  
Bellevue, WA 98008

## Member's Discounts

All members in good standing receive a membership card that will allow them to get a discount at the stores listed below:

**Crosscut Hardwoods**  
4100—1st Avenue S.,  
Seattle 98134  
**10% Discount**

**Rockler Woodworking**  
3823 Stone Way N.  
Seattle 98103  
**10% Discount (not valid on power tools)**

**Woodcraft Supply**  
5963 Corson S.,  
Seattle 98108  
**10% Discount (not valid on power tools or workbenches)**

**Edensaw Woods**  
8032 S. 194th St.  
Kent, WA 98032

Please present your current membership card to receive your discount.

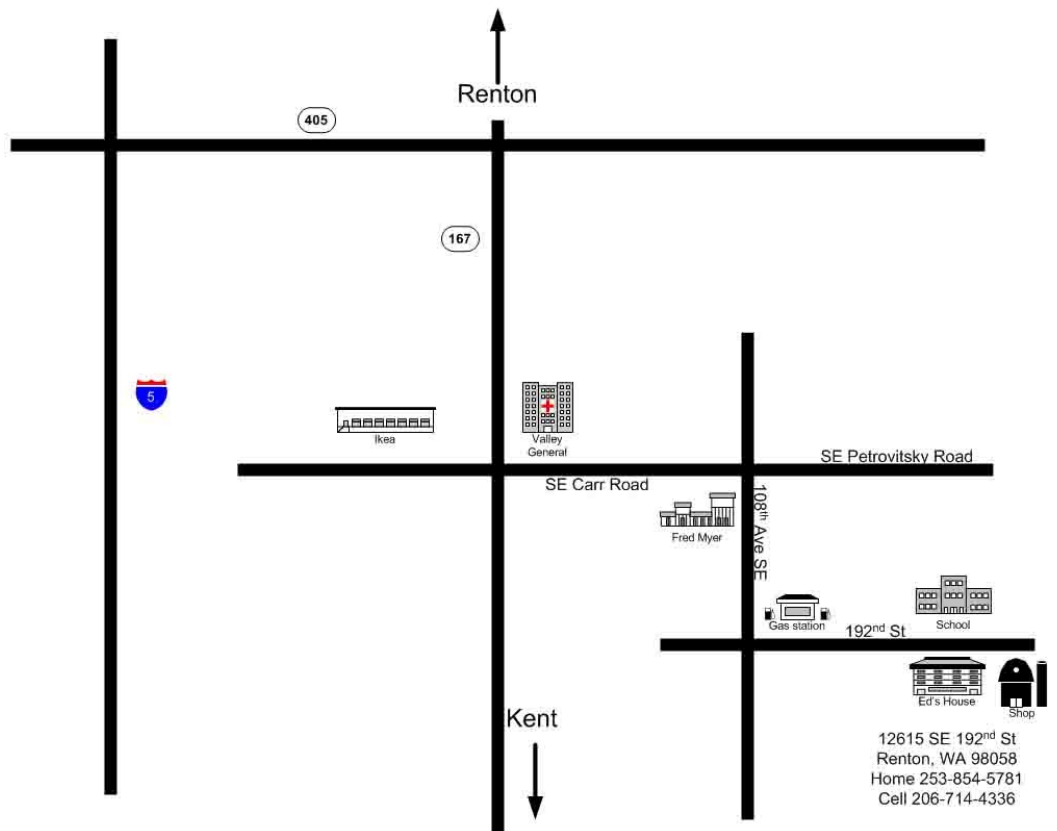

**July Meeting and Picnic: 12615 SE 192nd St, Renton, WA 98058—for additional help or directions, call Ed and Marly Moore, 253-854-5781**

## Members' Questions

Here is YOUR chance to help a member with a challenge:

“What is the legal certification process for wood stock coming from private property? Thanks, -Joshua Billings 206-769-4726” [jb9776@gmail.com](mailto:jb9776@gmail.com)

# May Meeting



## HOMEMADE HOLD-DOWNS CAN DO THE JOB

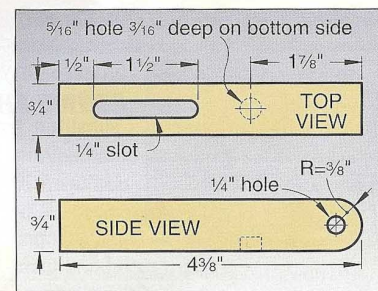
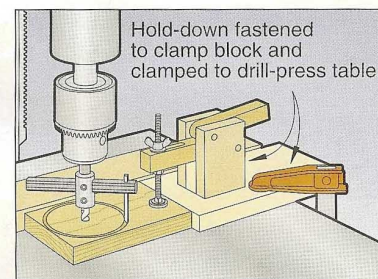
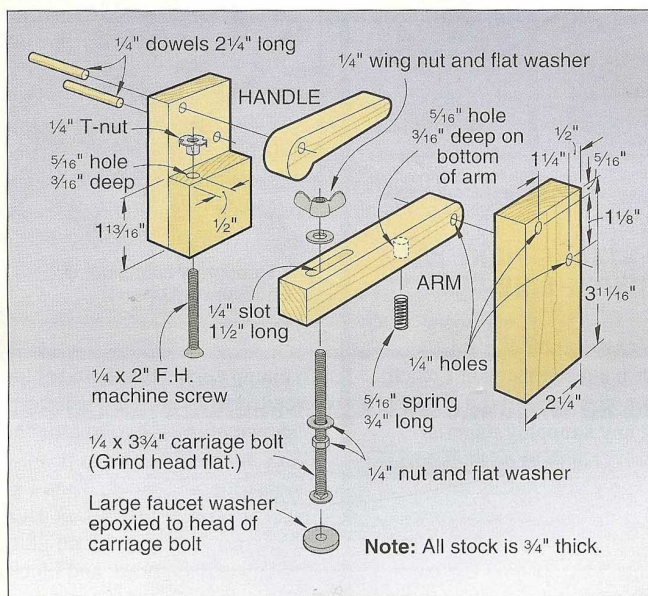

While building a project, I found myself needing a hold-down clamp. Because I live more than 200 miles from the nearest home improvement center, I thought I'd try to make my own. The clamp shown at *right* works so well, I've made several more since.

I cut the handle, arm, and base from scraps of hard maple. To make the shoe, I ground the head of a carriage bolt flat and epoxied a

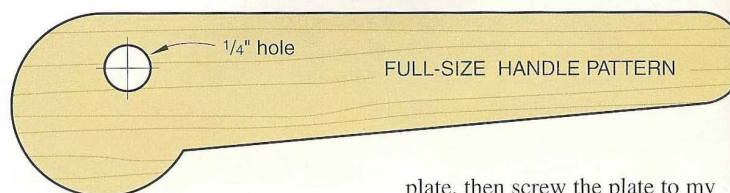

faucet washer to the head.

The clamp screws to a jig or fence from the bottom, but when that's a problem, I bolt it to a larger

plate, then screw the plate to my work surface. You can also accommodate thicker workpieces by making a taller base, or by inserting a spacer to raise the clamp height.

—Allan Kruger, Eagar, Arizona

# May Program

## CNC Routers by Mike Magruder

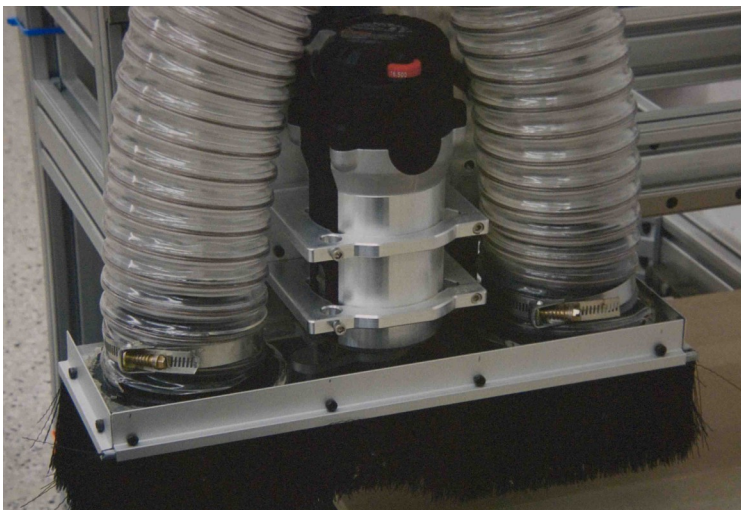
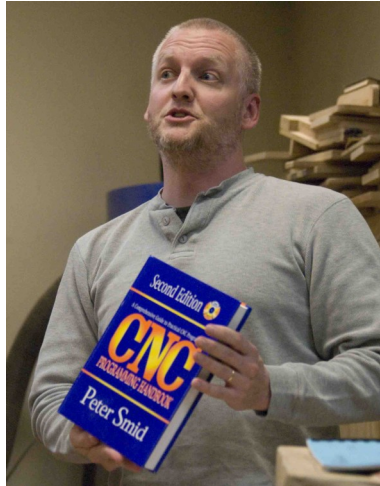
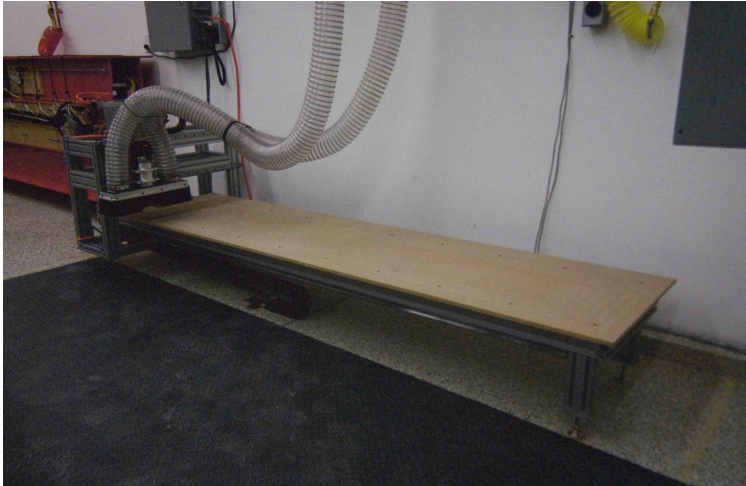

# May Show-And-Tell



# May Show-And-Tell

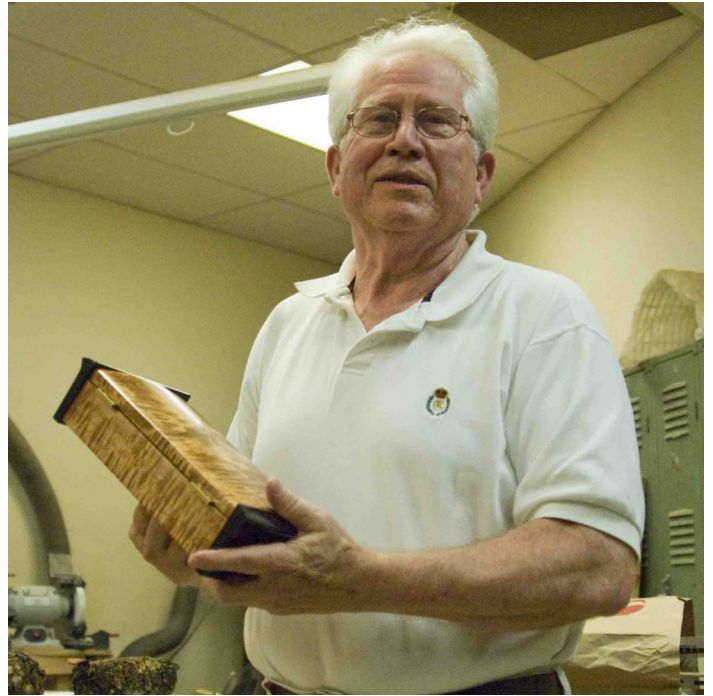

# Northwest Woodworker's Guild Picnic



Special Thanks to Ed and Marly Moore who are hosting our Picnic/July meeting for the third year in a row. Mark your calendar for Thursday, July 16<sup>th</sup> at Ed and Marly Moore's house in Renton. Everyone is welcome and we encourage you to bring your family, children, grandchildren. We will provide the beverages and entrees and ask each family to bring either a salad or dessert. Our tentative schedule is start about at 4:00 pm, meeting will be at 5:00 p m and the picnic/food will start at 6:00 p m. The picnic should be fun for everyone with good food, good weather and time to spend with your woodworking friends and family.

## Activities

- Great Food
- Time With Friends
- Woodworking Demos

## Northwest Woodworker's Guild

.....  
If you have questions or need additional contact Ed Moore or Jack Martin.

Contact Ed Marly: 253 854 5781(h) 206 714 4336 © or email [ed\\_marly@msn.com](mailto:ed_marly@msn.com)

Time: 4:00 PM

Date: July 16, 2009

# Northwest Woodworkers Proposal for election of Officers and Board Members

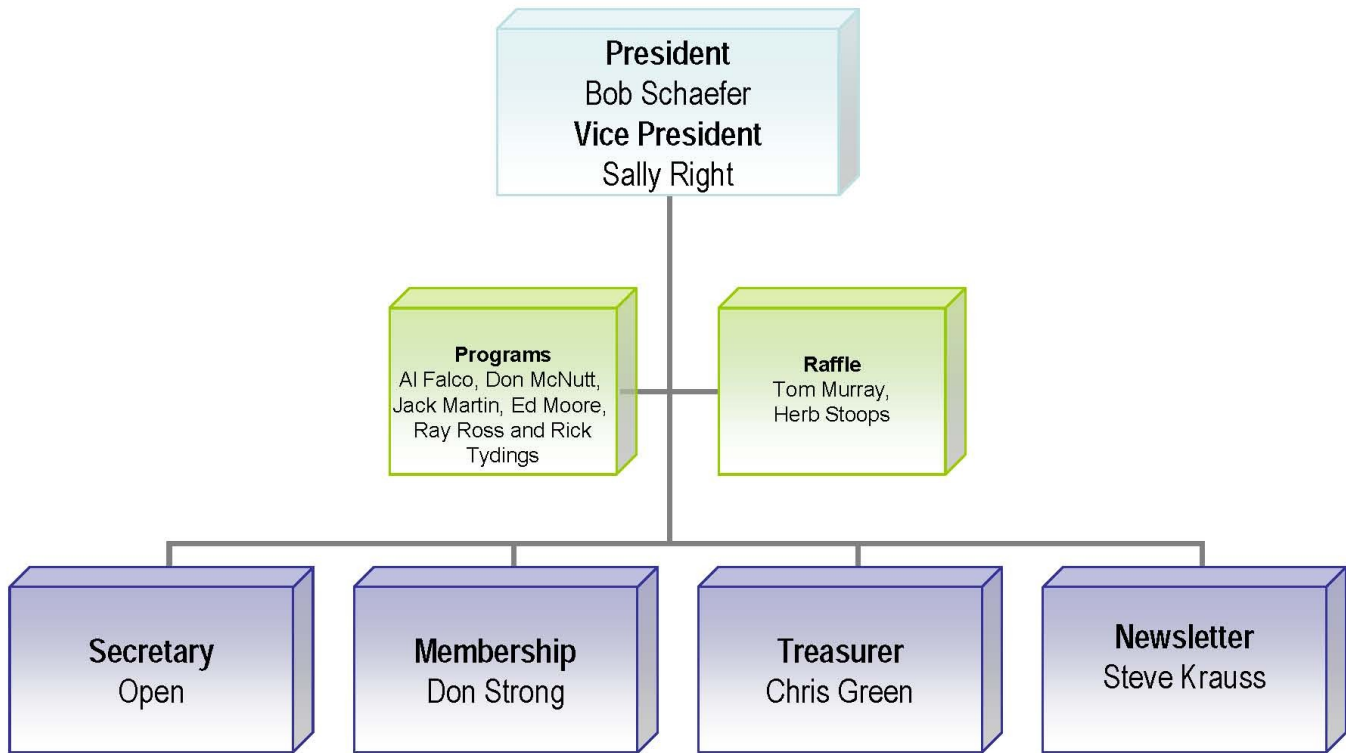

## Officer and Board Member Proposal for Election

— by Rick Tydings and Steve Krauss

**This is the updated proposed roster for the election of new officers and board members. Everyone on the chart has been contacted and we are looking for additional members who are interested in participating and running for an office or board position. We know there are additional members who would like to participate and contribute within the Northwest Woodworkers Guild, and you are encouraged to contact Jack Martin, Don Strong or Rick Tydings to get on the slate for the election. All members are eligible, and are encouraged to run for office and help lead the Guild.**